

PILLOBALLS

- PILLOBALL Spherical Bushings - Insert Type
- PILLOBALL Rod Ends - Insert Type
- PILLOBALL Rod Ends - Die-cast Type
- PILLOBALL Rod Ends - Maintenance-free Type



Structure and Features

IKO PILLOBALLS are compact self-aligning spherical bushings that can support a large radial load and a bi-directional axial load at the same time. These bushings are classified by sliding surface types, namely, insert type, die-cast type and maintenance-free type. In the insert type, a spherical inner ring makes contact with the special copper alloy bushing with superior run-in properties. In the die-cast type, a spherical inner ring makes direct contact with the bore surface of the body of special zinc die-cast alloy. In the maintenance-free type, a spherical inner ring makes contact with the special PTFE liner of maintenance-free type. Thus, a smooth rotational and oscillatory motion can be achieved with superior anti-wear and loading properties in each type. PILLOBALL Rod Ends have either a female thread in the body or a male thread on the body, and they can be easily assembled onto machines. PILLOBALLS are used in control and link mechanisms in machine tools, textile machines, packaging machines, etc. The maintenance-free type is especially suitable for loading in one direction and is the best choice for machines in which oil must be avoided such as food processing machines, or machines which cannot be re-lubricated.

Structures of maintenance-free type PILLOBALLS

PHS···EC

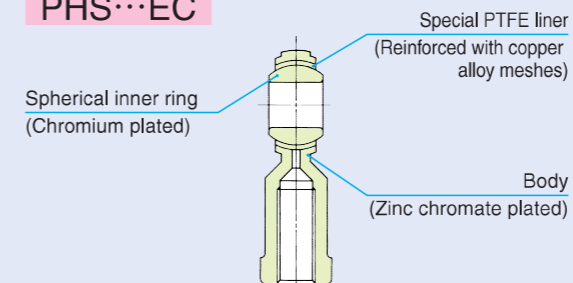

POS···EC

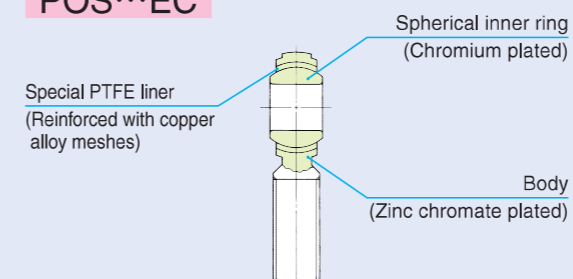

Structures of lubrication type PILLOBALLS

PB

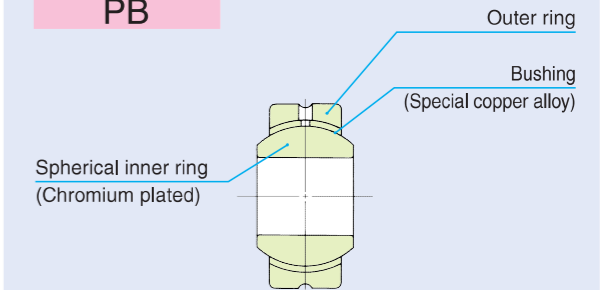

PHS·PHSB

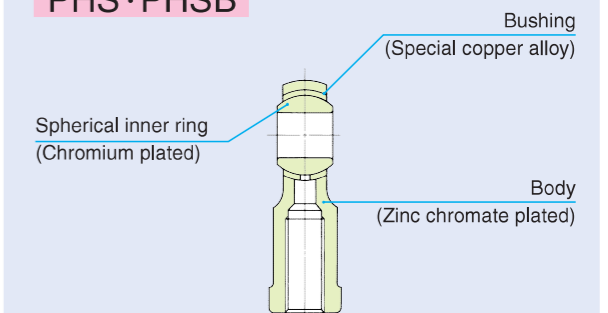

POS·POSB

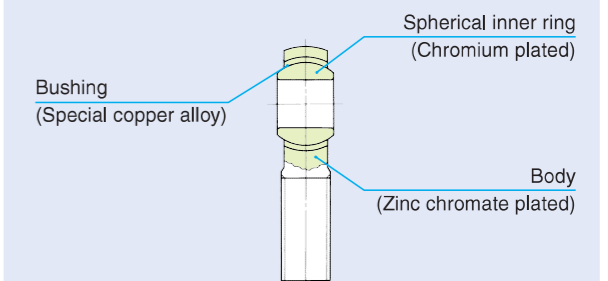

PHSA

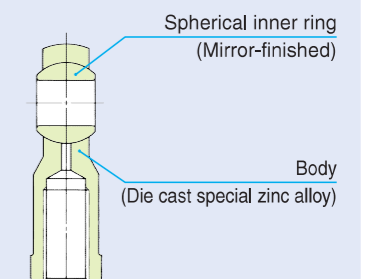

K

PB
PHS
PHSB
POS
POSB
PHSA

Types

In PILLOBALLs, the types shown in Table 1 are available.

Table 1 Type

Type	Lubrication type				Maintenance-free type	
	Spherical Bushings	Rod end		Rod end		
		female thread	male thread	female thread	male thread	
Insert type	PB	PHS · PHSB	POS · POSB	PHS···EC	POS···EC	
Die-cast type	—	PHSA	—			

Lubrication Type PILLOBALL Spherical Bushings Insert Type PB

This type has superior anti-wear properties and high rigidity. It consists of a spherical inner ring, an outer ring, and a bushing of special copper alloy with superior run-in properties inserted in between. The spherical surface of the inner ring is chromium plated after heat treatment and grinding. This type is assembled with a shaft and a housing.

When especially large radial and/or axial loads are applied, Spherical Bushings with molybdenum disulfide (MoS₂) treated inner and outer rings are recommended. (See page J17.)

Lubrication Type PILLOBALL Rod Ends Insert Type PHS, POS, PHSB and POSB

This type has superior anti-wear and anti-corrosion properties as well as high rigidity. It consists of a spherical inner ring of which spherical surface is chromium-plated after heat treatment and grinding, a body with a zinc chromate treated outer surface, and an inserted bushing of special copper alloy having superior run-in properties. This type includes PHS and PHSB, which has a female thread in the body, and POS and POSB, which has a male thread on the body

Lubrication Type PILLOBALL Rod Ends Die-cast Type PHSA

The spherical inner ring of this type is mirror-finished after heat treatment and is built in a body of die-cast special zinc alloy. The sliding surfaces of the inner ring and body are in close contact with each other. Thus, this type is an economical rod end with superior anti-wear and loading properties.

Maintenance-free Type PILLOBALL Rod Ends PHS···EC, POS···EC

This type has superior anti-corrosion properties as the body is zinc chromate treated and the spherical inner

ring is chromium plated on the sphere surface after heat treatment and grinding.

A special PTFE liner, reinforced with copper alloy meshes, which is superior in anti-wear properties with little creep deformation is used for lining on the sliding surface of the body, and this type is maintenance-free.

PHS···EC, which has a female thread in the body, and POS···EC, which has a male thread on the body, are available.

Identification number

The identification number of PILLOBALLs consists of a model code, a size and any supplemental codes as shown in the examples.

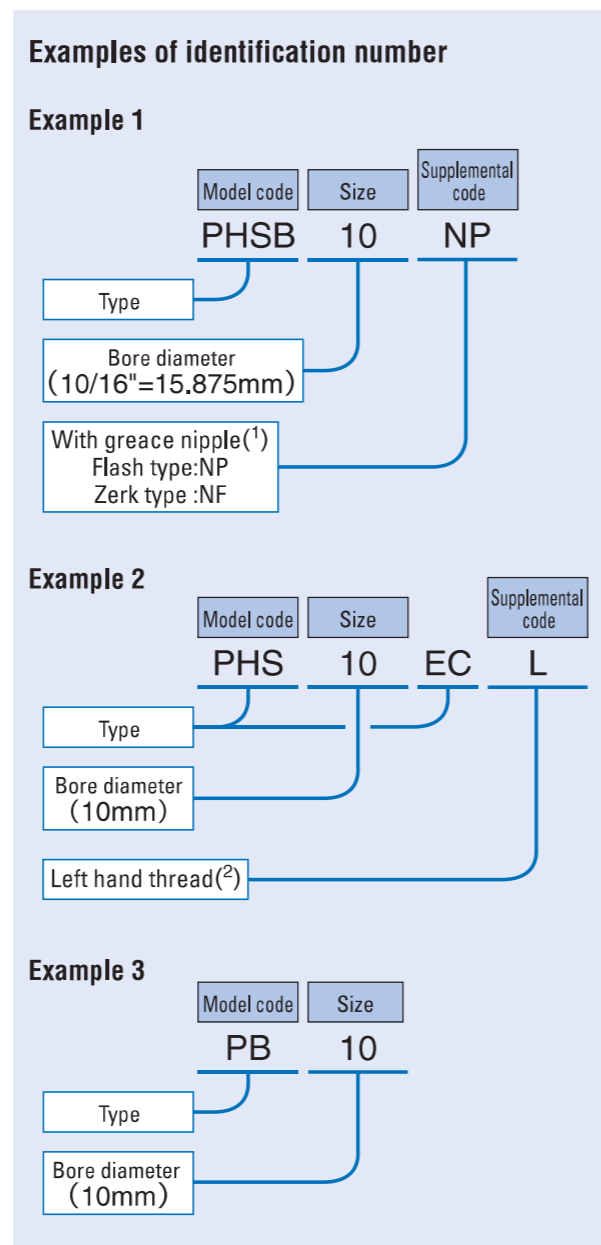

Notes⁽¹⁾ Shapes of grease nipple are shown in Fig.1.
⁽²⁾ Right hand thread is indicated with no code.

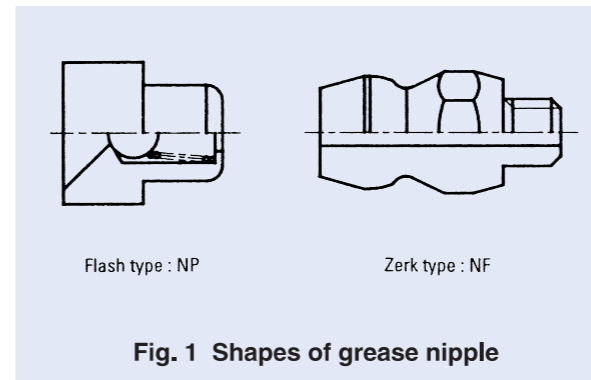

Accuracy

The accuracy of PILLOBALLs is shown in Tables 2 and 3. The maximum radial internal clearance of the insert type is 0.035 mm.

Table 2 Tolerance

Type	Dimension	Dimension symbol	Tolerance
PB	Bore dia. of inner ring	<i>d</i>	H7
	Outside dia. of outer ring	<i>D</i>	h6
	Width of inner ring	<i>B</i>	0 -0.1
	Width of outer ring	<i>C</i>	±0.1
PHS POS PHS···EC POS···EC	Bore dia. of inner ring	<i>d</i>	H7
	Width of inner ring	<i>B</i>	0 -0.1
PHSB POSB	Bore dia. of inner ring	<i>d</i>	+0.038 -0.013
	Width of inner ring	<i>B</i> ₁	0 -0.127
PHSA	Bore dia. of inner ring	<i>d</i>	+0.063 -0.012
	Width of inner ring	<i>B</i>	See Table 3.

Table 3 Tolerance of width *B* of inner ring of PHSA type unit: mm

<i>d</i> Nominal bore dia. of inner ring	Incl.	ΔB_s Deviation of a single inner ring width	
		High	Low
—	14	0	-0.2
14	20	0	-0.3
20	22	0	-0.4

Fit

Recommended fits for PILLOBALLs are shown in Table 4.

Table 4 Recommended fits

Condition	Tolerance class	
	Shaft	Housing bore ⁽¹⁾
Normal operation	h7	H7
Directionally indeterminate loading	n6, p6	N7

Note⁽¹⁾ This is applicable to PILLOBALL Spherical Bushings, Insert type.

Selection of PILLOBALL

Load capacities of PILLOBALLs are determined based on the allowable contact pressure on sliding surfaces and the strength of body for each type. Thus, a suitable type and size should be selected based on the dynamic load capacity *C_d* and static load capacity *C_s* shown in the dimension tables.

Load capacity

① Dynamic load capacity

The dynamic load capacity *C_d* is obtained on the basis of the contact pressure on the sliding surface. The dynamic load capacity is used for calculating the life.

The dynamic load capacity considering temperature increase is obtained from the following equation using the temperature factor, which is a correction factor for the effect of PILLOBALL temperature.

$$C_{dt} = f_t C_d \dots \dots \dots (1)$$

where, *C_{dt}* : Dynamic load capacity considering temperature increase, N

f_t : Temperature factor (Refer to Table 5.)

C_d : Dynamic load capacity, N (Refer to the dimension tables.)

Table 5 Temperature factor *f_t*

Type	Temperature °C					
	-30 +80	+80 +90	+90 +100	+100 +120	+120 +150	+150 +180
PB PHS, POS PHSB, POSB	1	1	1	1	1	0.7
PHS···EC POS···EC	1	1	0.9	0.75	0.55	—

② Static load capacity

The static load capacity *C_s* is the maximum static load that can be applied on the PILLOBALL without breaking the inner or outer ring of the PILLOBALL Spherical Bushing (or the inner ring or body of the PILLOBALL Rod End), and without causing severe permanent deformation that will make the PILLOBALL unusable.



Maximum Operating Load

The recommended value of bushing load is obtained by multiplying the dynamic load capacity C_d by a numerical factor, which differs depending on the bushing type and load condition. For PILLOBALL Rod Ends, the static load capacity C_s must also be considered in determining the applicable bushing load. Table 6 shows the guidelines for maximum operating load of PILLOBALLS. When axial loads are added in addition to radial loads, bending stress occurs in the body. Pay attention to this bending stress.

Table 6 Maximum operating load

Type	Load direction	
	Constant	Alternate
PB	$\leq 0.3C_d (\leq C_s)$	$\leq 0.6C_d$
PHS,POS,PHSB,POSB	$\leq 0.3C_d (\leq 0.3C_s)$	$(\leq 0.6C_d) \leq 0.2C_s$
PHSA	$\leq 0.16C_s$	
PHS...EC,POS...EC	$(\leq C_d)$	$(\leq 0.5C_d) \leq 0.2C_s$

Remark C_d is the dynamic load capacity and C_s is the static load capacity.
When the magnitude of applied load is within the value shown outside the parenthesis, it is also within the value in the parenthesis.

Equivalent radial load

PILLOBALLS can take radial and axial loads at the same time. When the magnitude and direction of loads are constant, the equivalent radial load can be obtained by the following formula.

$$P = F_r + YF_a \quad (2)$$

where, P : Equivalent radial load, N

F_r : Radial load, N

F_a : Axial load, N

Y : Axial load factor (Refer to Table 7.)

Table 7 Axial load factor Y

Type	F_a/F_r					
	0.1	0.2	0.3	0.4	0.5	> 0.5
PB	1	2	3	4	5	Unusable
PHS,POS	1	2	3	4	5	Unusable
PHSB,POSB	1	2	3	4	5	Unusable
PHS...EC	1	2	3	Unusable		
POS...EC	1	2	3	Unusable		

Life

The life of PILLOBALLS is defined as the total number of oscillating motions during which the PILLOBALLS can be operated without failure or malfunction due to wear, increase in internal clearance, increase in sliding torque and operating temperature, etc.

As the actual life is affected by many factors such as the material of the sliding surface, the magnitude and direction of load, lubrication, sliding velocity, etc., the calculated life can be used as a measure of expected service life.

① Life of lubrication type PILLOBALLS PB · PHS · POS · PHSB · POSB

[1] Confirmation of pV value

Before attempting to calculate the life, make sure that the operating conditions are within the permissible range by referring to the pV diagram in Fig.2.

When the operating conditions are out of the permissible range, please consult IKO.

The contact pressure p and the sliding velocity V are obtained from the following formulae.

$$p = \frac{50P}{C_{dt}} \quad (3)$$

$$V = 5.82 \times 10^{-4} d_k \beta f \quad (4)$$

where, p : Contact pressure, N/mm²

P : Equivalent radial load, N

(Refer to Formula (2).)

C_{dt} : Dynamic load capacity considering temperature increase, N

(Refer to Formula (1).)

V : Sliding velocity, mm/s

d_k : Sphere diameter, mm

(Refer to the dimensional tables.)

2β : Oscillating angle degrees (Refer to Fig.2.)

when $\beta < 5^\circ$, $\beta = 5$

when rotating, $\beta = 90$

f : Number of oscillations per minute, cpm

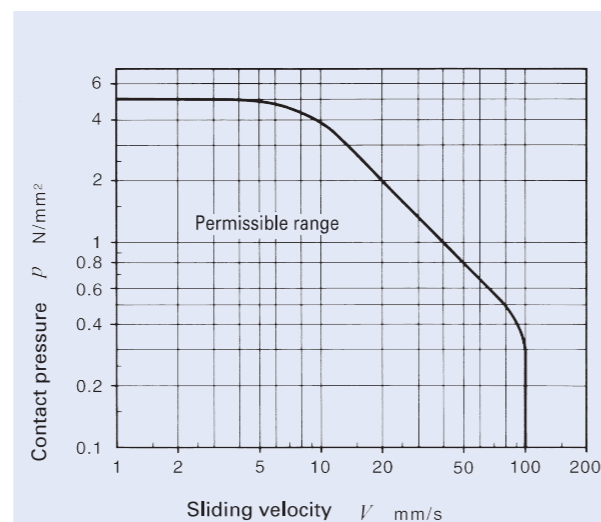

Fig. 2 pV diagram of lubrication type PILLOBALLS

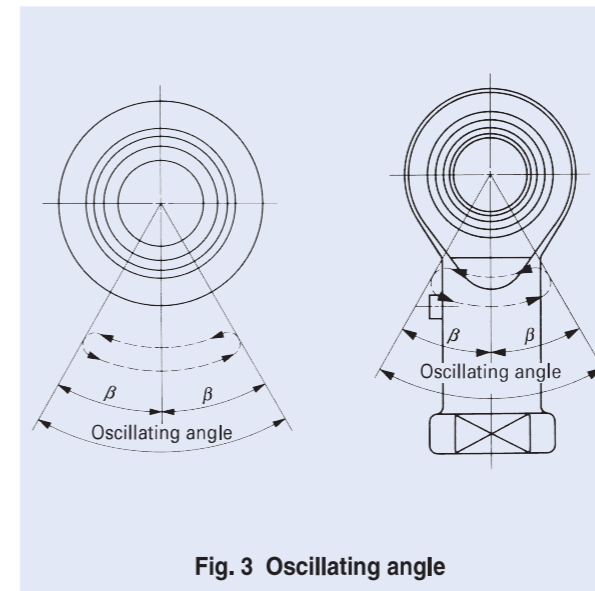

Fig. 3 Oscillating angle

[2] Life calculation

The life of lubrication type PILLOBALLS can be calculated by the following formulae.

$$G = \frac{3.18b_1b_2b_3}{\sqrt{d_k\beta}} \left(\frac{C_{dt}}{P}\right)^2 \times 10^5 \quad (5)$$

$$L_h = \frac{G}{60f} \quad (6)$$

where, G : Life (Total number of oscillations)

b_1 : Load directional factor (Refer to Table 8.)

b_2 : Lubrication factor (Refer to Table 8.)

b_3 : Sliding velocity factor (Refer to Fig. 3.)

C_{dt} : Dynamic load capacity considering temperature increase, N

(Refer to Formula (1).)

P : Equivalent radial load, N

(Refer to Formula (2).)

L_h : Life in hours, h

f : Number of oscillations per minute, cpm

Table 8 Load directional factor b_1 and lubrication factor b_2 for lubrication type PILLOBALLS

Load directional factor b_1		Lubrication factor b_2	
Load direction		Periodical lubrication	
Constant	Alternate	None	Regular
1	5	1	15

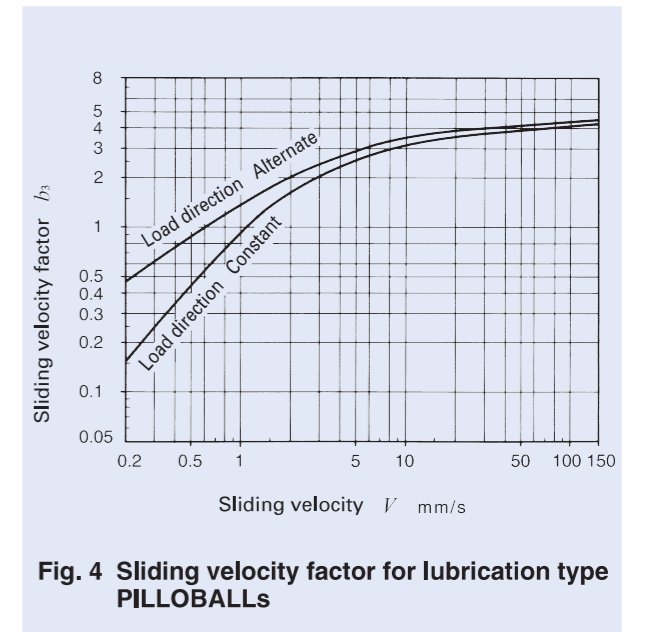

Fig. 4 Sliding velocity factor for lubrication type PILLOBALLS

② Life of maintenance-free type PILLOBALLS PHS...EC·POS...EC

[1] Confirmation of pV value

Before attempting to calculate the life, make sure that the operating conditions are within the permissible range by referring to the pV diagram in Fig.4.

When the operating conditions are out of the permissible range, please consult IKO.

The contact pressure p and sliding velocity V are obtained from Formulae (3) and (4) on page K6.

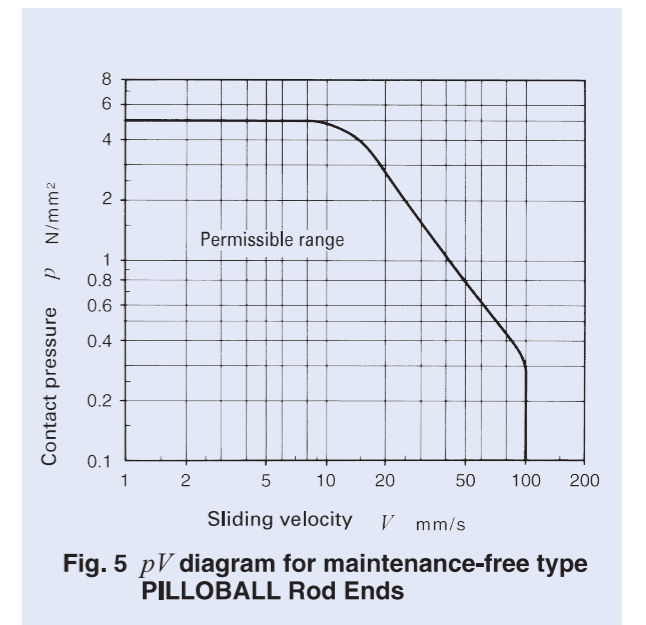

Fig. 5 pV diagram for maintenance-free type PILLOBALL Rod Ends

[2] Life calculation

The life of maintenance-free type PILLOBALL Rod Ends is obtained from the total sliding distance S which is given in Fig.5 for the contact pressure p obtained from Formula (3).

The total number of oscillations and life in hours can be obtained from the following formulae.

$$G = 16.67 \times b_1 \times \frac{Sf}{V} \dots\dots\dots(7)$$

$$L_h = \frac{G}{60f} \dots\dots\dots(8)$$

- where, G : Life (Total number of oscillations)
 b_1 : Load directional factor (Refer to Table 9.)
 S : Total sliding distance m
 f : Number of oscillations per minute cpm
 V : Sliding velocity mm/s
 L_h : Life in hours h

Table 9 Load directional factor for maintenance-free type PILLOBALLs b_1

Load direction	Constant	Alternate
Load directional factor b_1	1	0.2 ⁽¹⁾

Note⁽¹⁾ This value is applicable when the load changes comparatively slowly. When the load changes rapidly, please consult IKO, as the factor degrades sharply.

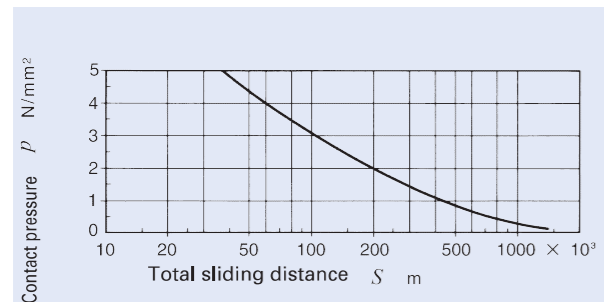

Fig. 6 Contact pressure and total sliding distance for maintenance-free type PILLOBALL Rod Ends

Lubrication

Maintenance-free type PILLOBALL Rod Ends have a sliding surface lined with a self-lubricating lining. Therefore, they can be used without lubrication.

Lubrication type PILLOBALLs are not provided with prepacked grease. Perform proper lubrication for use. Operating without lubrication will increase the wear of the sliding contact surfaces and cause seizure.

Oil Hole and Grease Nipple

Table 10 shows the specifications of oil hole and grease nipple on the outer ring or body. When a grease gun that fits the grease nipple is required, please contact IKO.

For PILLOBALLs without an oil hole and grease nipple, apply grease directly on the spherical surface.

Table 10 Specifications of oil hole and grease nipple

Type	Specification	
PB	1 oil hole + oil groove	
PHS	$d \leq 4$	None
	$4 < d$	With grease nipple
POS	$d \leq 4$	None
	$4 < d \leq 6$	1 oil hole
	$6 < d$	With grease nipple
PHSA	With grease nipple	
PHS...EC, POS...EC	None	

Operating Temperature Range

The maximum allowable temperature for Lubrication type PILLOBALLs is +180°C for the insert type and +80°C for the die-cast type.

The maximum allowable temperature for Maintenance-free type PILLOBALL Rod Ends is +150°C.

Precautions for Use

① Tightening depth

The recommended tightening depth of the screw into the PILLOBALL Rod End body is shown below.

Insert type and maintenance-free type: 1.25 times the nominal thread dia. or more.

Die-cast type: 2 times the nominal thread dia. or more.

② Allowable tilting angle

The allowable tilting angle differs depending on the mounting structure as shown in Table 11.

Table 11 Allowable tilting angle

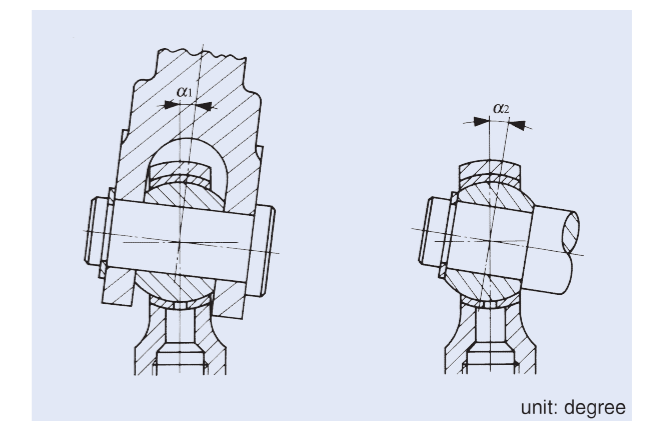

d Bore diameter mm	PB ⁽¹⁾ , PHS, POS PHS...EC, POS...EC		PHSA	
	α_1	α_2	α_1	α_2
3	7	13	—	—
4	7	13	—	—
5	8	13	7	13
6	8	13	7	13
8	8	14	8	14
10	8	14	8	14
12	8	13	8	13
14	10	16	9	16
16	9	15	9	15
18	9	15	9	15
20	9	15	9	15
22	10	15	9	15
25	9	15	—	—
28	9	15	—	—
30	10	17	—	—

Note⁽¹⁾ In the case of the PB series, α_2 is applicable in general.

Table 12 Allowable tilting angle for inch series

With female thread	With male thread	α_1	α_2
PHSB 2	POSB 2	8	16
PHSB 2.5	POSB 2.5	7	12
PHSB 3	POSB 3	6	10
PHSB 4	POSB 4	7	13
PHSB 5	POSB 5	6	10
PHSB 6	POSB 6	6	11
PHSB 7	POSB 7	7	11
PHSB 8	POSB 8	6	9
PHSB 10	POSB 10	7	11
PHSB 12	POSB 12	6	10
PHSB 16	POSB 16	7	14

PILLOBALL

Lubrication Type PILLOBALL Spherical Bushings **Insert Type**

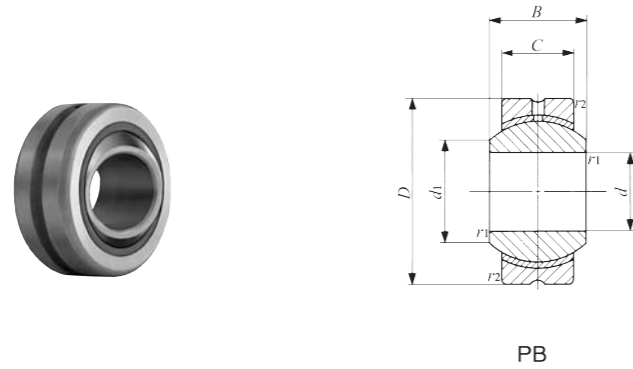

PB

Identification number	Mass (Ref.) g	Boundary dimensions mm							Dynamic load capacity C_d N	Static load capacity C_s N
		d	D	C	B	d_1	$r_s^{(1)}$ min	Ball dia. mm (inch)		
PB 5	8.5	5	16	6	8	7.7	0.2	11.112 ($\frac{7}{16}$)	3 270	7 850
PB 6	13	6	18	6.75	9	9	0.2	12.700 ($\frac{1}{2}$)	4 200	10 100
PB 8	24	8	22	9	12	10.4	0.2	15.875 ($\frac{5}{8}$)	7 010	16 800
PB 10	39	10	26	10.5	14	12.9	0.2	19.050 ($\frac{3}{4}$)	9 810	23 500
PB 12	58	12	30	12	16	15.4	0.2	22.225 ($\frac{7}{8}$)	13 100	31 400
PB 14	84	14	34	13.5	19	16.9	0.3	25.400 (1)	16 800	40 400
PB 16	111	16	38	15	21	19.4	0.3	28.575 ($1\frac{1}{8}$)	21 000	50 400
PB 18	160	18	42	16.5	23	21.9	0.3	31.750 ($1\frac{1}{4}$)	25 700	61 600
PB 20	210	20	46	18	25	24.4	0.3	34.925 ($1\frac{3}{8}$)	30 800	74 000
PB 22	265	22	50	20	28	25.8	0.3	38.100 ($1\frac{1}{2}$)	37 400	89 700
PB 25	390	25	56	22	31	29.6	0.6	42.862 ($1\frac{11}{16}$)	46 200	111 000
PB 28	410	28	62	25	35	32.3	0.6	47.625 ($1\frac{7}{8}$)	58 400	140 000
PB 30	610	30	66	25	37	34.8	0.6	50.800 (2)	62 300	149 000

Note⁽¹⁾ Minimum allowable value of chamfer dimensions r_1 and r_2
 Remarks1. The outer ring has an oil groove and an oil hole.
 2. Not provided with prepacked grease. Perform proper lubrication for use.

Lubrication Type PILLOBALL Rod Ends **Insert Type/With Female Thread**

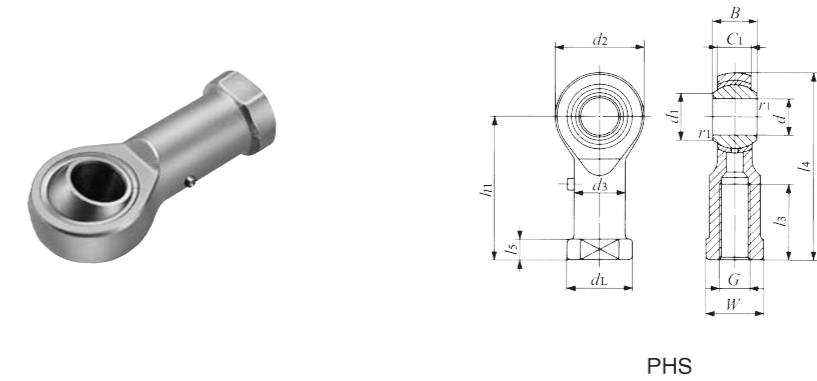

PHS

Identification number	Mass (Ref.) g	Boundary dimensions mm														Dynamic load capacity C_d N	Static load capacity C_s N	
		d	Thread G	d_2	C_1	B	d_1	l_4	h_1	l_3	l_5	W	d_3	d_L	$r_s^{(1)}$ min			Ball dia. mm (inch)
PHS 3	5.7	3	M 3×0.5	12	4.5	6	5.2	27	21	10	3	5.5	5	6.5	0.2	7.938 ($\frac{5}{16}$)	1 750	3 670
PHS 4	11.9	4	M 4×0.7	14	5.3	7	6.5	31	24	12	4	8	8	9.5	0.2	9.525 ($\frac{3}{8}$)	2 480	4 680
PHS 5	16.5	5	M 5×0.8	16	6	8	7.7	35	27	14	4	9	9	11	0.2	11.112 ($\frac{7}{16}$)	3 270	5 730
PHS 6	25	6	M 6×1	18	6.75	9	9	39	30	14	5	11	10	13	0.2	12.700 ($\frac{1}{2}$)	4 200	6 910
PHS 8	43	8	M 8×1.25	22	9	12	10.4	47	36	17	5	14	12.5	16	0.2	15.875 ($\frac{5}{8}$)	7 010	10 200
PHS 10	72	10	M10×1.5	26	10.5	14	12.9	56	43	21	6.5	17	15	19	0.2	19.050 ($\frac{3}{4}$)	9 810	13 300
PHS 12	107	12	M12×1.75	30	12	16	15.4	65	50	24	6.5	19	17.5	22	0.2	22.225 ($\frac{7}{8}$)	13 100	16 900
PHS 14	160	14	M14×2	34	13.5	19	16.9	74	57	27	8	22	20	25	0.2	25.400 (1)	16 800	20 900
PHS 16	210	16	M16×2	38	15	21	19.4	83	64	33	8	22	22	27	0.2	28.575 ($1\frac{1}{8}$)	21 000	25 400
PHS 18	295	18	M18×1.5	42	16.5	23	21.9	92	71	36	10	27	25	31	0.2	31.750 ($1\frac{1}{4}$)	25 700	30 200
PHS 20	380	20	M20×1.5	46	18	25	24.4	100	77	40	10	30	27.5	34	0.2	34.925 ($1\frac{3}{8}$)	30 800	35 500
PHS 22	490	22	M22×1.5	50	20	28	25.8	109	84	43	12	32	30	37	0.2	38.100 ($1\frac{1}{2}$)	37 400	41 700
PHS 25	750	25	M24×2	60	22	31	29.6	124	94	48	12	36	33.5	42	0.6	42.862 ($1\frac{11}{16}$)	46 200	72 700
PHS 28	950	28	M27×2	66	25	35	32.3	136	103	53	12	41	37	46	0.6	47.625 ($1\frac{7}{8}$)	58 400	87 000
PHS 30	1 130	30	M30×2	70	25	37	34.8	145	110	56	15	41	40	50	0.6	50.800 (2)	62 300	92 200

Note⁽¹⁾ Minimum allowable value of chamfer dimension r_1
 Remarks1. Neither oil hole nor grease nipple is provided for PHS with an inner ring bore diameter d of 4 mm or less. For others, a grease nipple is provided on the body.
 2. Not provided with prepacked grease. Perform proper lubrication for use.
 3. When a metric fine thread specification is required, please contact IKO.

PILLOBALL

Lubrication Type PILLOBALL Rod Ends **Insert Type/With Male Thread**

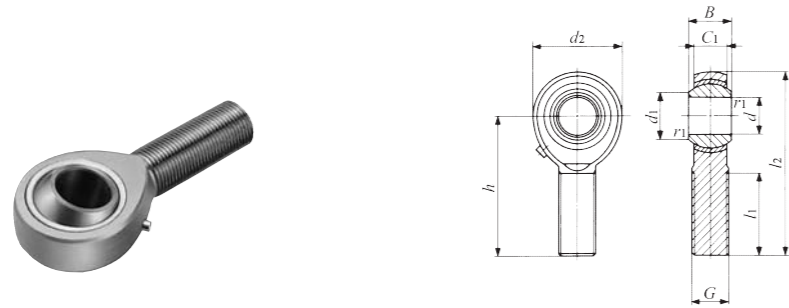

POS

Identification number	Mass (Ref.) g	Boundary dimensions mm										Dynamic load capacity C_d N	Static load capacity C_s N	
		d	Thread G	d_2	C_1	B	d_1	l_2	h	l_1	$r_{1s\min}^{(1)}$			Ball dia. mm (inch)
POS 3	5.0	3	M 3×0.5	12	4.5	6	5.2	33	27	15	0.2	7.938 ($\frac{5}{16}$)	1 750	1 220
POS 4	8.1	4	M 4×0.7	14	5.3	7	6.5	37	30	17	0.2	9.525 ($\frac{3}{8}$)	2 480	2 060
POS 5	12.5	5	M 5×0.8	16	6	8	7.7	41	33	20	0.2	11.112 ($\frac{7}{16}$)	3 270	3 340
POS 6	19	6	M 6×1	18	6.75	9	9	45	36	22	0.2	12.700 ($\frac{1}{2}$)	4 200	4 730
POS 8	32	8	M 8×1.25	22	9	12	10.4	53	42	25	0.2	15.875 ($\frac{5}{8}$)	7 010	8 640
POS 10	54	10	M10×1.5	26	10.5	14	12.9	61	48	29	0.2	19.050 ($\frac{3}{4}$)	9 810	13 300
POS 12	85	12	M12×1.75	30	12	16	15.4	69	54	33	0.2	22.225 ($\frac{7}{8}$)	13 100	16 900
POS 14	126	14	M14×2	34	13.5	19	16.9	77	60	36	0.2	25.400 (1)	16 800	20 900
POS 16	185	16	M16×2	38	15	21	19.4	85	66	40	0.2	28.575 ($1\frac{1}{8}$)	21 000	25 400
POS 18	260	18	M18×1.5	42	16.5	23	21.9	93	72	44	0.2	31.750 ($1\frac{1}{4}$)	25 700	30 200
POS 20	340	20	M20×1.5	46	18	25	24.4	101	78	47	0.2	34.925 ($1\frac{3}{8}$)	30 800	35 500
POS 22	435	22	M22×1.5	50	20	28	25.8	109	84	51	0.2	38.100 ($1\frac{1}{2}$)	37 400	41 700
POS 25	650	25	M24×2	60	22	31	29.6	124	94	57	0.6	42.862 ($1\frac{11}{16}$)	46 200	72 700
POS 28	875	28	M27×2	66	25	35	32.3	136	103	62	0.6	47.625 ($1\frac{7}{8}$)	58 400	87 000
POS 30	1 070	30	M30×2	70	25	37	34.8	145	110	66	0.6	50.800 (2)	62 300	92 200

Note⁽¹⁾ Minimum allowable value of chamfer dimension r_1
 Remarks1. Neither oil hole nor grease nipple is provided for POS with an inner ring bore diameter d of 4 mm or less.
 For those with an inner ring bore diameter d of 5 to 6 mm, an oil hole is provided on the body. For others, a grease nipple is provided on the body.
 2. Not provided with prepacked grease. Perform proper lubrication for use.
 3. When a metric fine thread specification is required, please contact IKO.

Inch series PILLOBALL Rod Ends **Insert Type/With Female Thread**

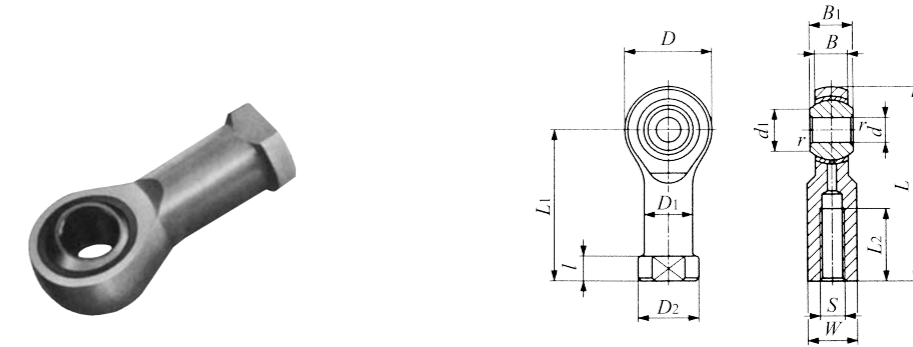

PHSB

Identification number	Mass (Ref.) g	Boundary dimensions mm(inch)																Dynamic load capacity C_d N	Static load capacity C_s N
		d	Thread S class 3B	D	B	B_1	d_1	L	l	L_1	L_2	W	D_1	D_2	$r_{s\min}^{(1)}$	Ball dia. mm (inch)			
PHSB 2	6.8	3.175 (.1250)	-32UNC (.1380)	11.91 (.469)	4.75 (.187)	6.35 (.250)	4.75 (.187)	26.57 (1.046)	4.75 (.187)	20.62 (.812)	9.53 (.375)	6.35 (.250)	6.35 (.250)	7.92 (.312)	0.3 (.012)	7.938 ($\frac{5}{16}$)	1 850	5 840	
PHSB 2.5	11	3.967 (.1562)	-32UNC (.1640)	14.27 (.562)	5.56 (.219)	7.14 (.281)	6.32 (.249)	29.36 (1.156)	4.75 (.187)	22.23 (.875)	9.53 (.375)	7.14 (.281)	7.14 (.281)	8.74 (.344)	0.3 (.012)	9.525 ($\frac{3}{8}$)	2 600	8 210	
PHSB 3	14	4.826 (.1900)	-32UNF (.1900)	15.88 (.625)	6.35 (.250)	7.92 (.312)	7.77 (.306)	34.93 (1.375)	4.75 (.187)	26.97 (1.062)	14.27 (.562)	7.92 (.312)	7.92 (.312)	10.31 (.406)	0.3 (.012)	11.112 ($\frac{7}{16}$)	3 460	9 090	
PHSB 4	23	6.350 (.2500)	-28UNF (.2500)	19.05 (.750)	7.14 (.281)	9.53 (.375)	9.02 (.355)	42.85 (1.687)	4.75 (.187)	33.32 (1.312)	19.05 (.750)	9.53 (.375)	9.53 (.375)	11.89 (.468)	0.5 (.020)	13.097 ($\frac{33}{64}$)	4 590	13 200	
PHSB 5	36	7.938 (.3125)	-24UNF (.3125)	22.23 (.875)	8.74 (.344)	11.10 (.437)	11.35 (.447)	46.02 (1.812)	4.75 (.187)	34.93 (1.375)	19.05 (.750)	11.10 (.437)	11.10 (.437)	12.70 (.500)	0.5 (.020)	15.875 ($\frac{5}{8}$)	6 800	16 500	
PHSB 6	59	9.525 (.3750)	-24UNF (.3750)	25.40 (1.000)	10.31 (.406)	12.70 (.500)	13.13 (.517)	53.98 (2.125)	6.35 (.250)	41.28 (1.625)	23.80 (.937)	14.27 (.562)	14.27 (.562)	17.45 (.687)	0.5 (.020)	18.256 ($\frac{23}{32}$)	9 230	21 600	
PHSB 7	82	11.112 (.4375)	-20UNF (.4375)	28.58 (1.125)	11.10 (.437)	14.27 (.562)	14.88 (.586)	60.33 (2.375)	6.35 (.250)	46.02 (1.812)	26.97 (1.062)	15.88 (.625)	15.88 (.625)	19.05 (.750)	0.5 (.020)	20.638 ($\frac{13}{16}$)	11 200	26 100	
PHSB 8	132	12.700 (.5000)	-20UNF (.5000)	33.32 (1.312)	12.70 (.500)	15.88 (.625)	17.73 (.698)	70.64 (2.781)	6.35 (.250)	53.98 (2.125)	30.15 (1.187)	19.05 (.750)	19.05 (.750)	22.23 (.875)	0.5 (.020)	23.812 ($\frac{15}{16}$)	14 800	36 200	
PHSB 10	191	15.875 (.6250)	-18UNF (.6250)	38.10 (1.500)	14.27 (.562)	19.05 (.750)	21.31 (.839)	82.55 (3.250)	7.92 (.312)	63.50 (2.500)	38.10 (1.500)	22.23 (.875)	22.23 (.875)	25.40 (1.000)	0.5 (.020)	28.575 ($1\frac{1}{8}$)	20 000	39 300	
PHSB 12	286	19.050 (.7500)	-16UNF (.7500)	44.45 (1.750)	17.45 (.687)	22.23 (.875)	24.84 (.978)	95.25 (3.750)	7.92 (.312)	73.03 (2.875)	44.45 (1.750)	25.40 (1.000)	25.40 (1.000)	28.58 (1.125)	0.5 (.020)	33.338 ($1\frac{5}{16}$)	28 500	55 000	
PHSB 16	998	25.400 (1.0000)	-12UNF (1.2500)	69.85 (2.750)	25.40 (1.000)	34.93 (1.375)	32.23 (1.269)	139.70 (5.500)	11.07 (.436)	104.78 (4.125)	53.98 (2.125)	38.10 (1.500)	38.10 (1.500)	44.45 (1.750)	0.5 (.020)	47.625 ($1\frac{7}{8}$)	59 300	86 800	

Note⁽¹⁾ $r_{s\min}$ stands for minimum allowable value of chamfer r .



PILLOBALL

Inch series PILLOBALL Rod Ends **Insert Type/With Male Thread**

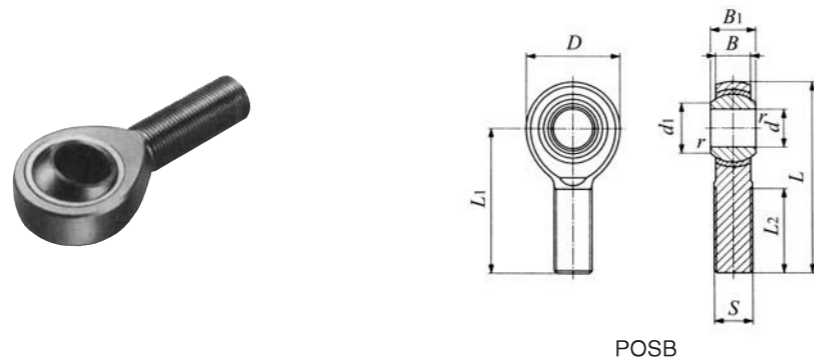

POSB

Identification number	Mass (Ref.) g	Boundary dimensions mm(inch)											Dynamic load capacity C_d N	Static load capacity C_s N
		d	Thread S class 3A	D	B	B_1	d_1	L	L_1	L_2	$r_{s\ min}^{(1)}$	Ball dia. mm (inch)		
POSB 2	5.4	3.175 (.1250)	-32UNC (.1380)	11.91 (.469)	4.75 (.187)	6.35 (.250)	4.75 (.187)	29.77 (1.172)	23.80 (.937)	12.70 (.500)	0.3 (.012)	7.938 ($\frac{3}{16}$)	1 850	2 160
POSB 2.5	9.1	3.967 (.1562)	-32UNC (.1640)	14.27 (.562)	5.56 (.219)	7.14 (.281)	6.32 (.249)	35.71 (1.406)	28.58 (1.125)	15.88 (.625)	0.3 (.012)	9.525 ($\frac{3}{8}$)	2 600	3 370
POSB 3	14	4.826 (.1900)	-32UNF (.1900)	15.88 (.625)	6.35 (.250)	7.92 (.312)	7.77 (.306)	39.70 (1.563)	31.75 (1.250)	19.05 (.750)	0.3 (.012)	11.112 ($\frac{7}{16}$)	3 460	4 850
POSB 4	23	6.350 (.2500)	-28UNF (.2500)	19.05 (.750)	7.14 (.281)	9.53 (.375)	9.02 (.355)	49.20 (1.937)	39.67 (1.562)	25.40 (1.000)	0.5 (.020)	13.097 ($\frac{39}{64}$)	4 590	8 870
POSB 5	36	7.938 (.3125)	-24UNF (.3125)	22.23 (.875)	8.74 (.344)	11.10 (.437)	11.35 (.447)	58.72 (2.312)	47.63 (1.875)	31.75 (1.250)	0.5 (.020)	15.875 ($\frac{5}{8}$)	6 800	14 200
POSB 6	54	9.525 (.3750)	-24UNF (.3750)	25.40 (1.000)	10.31 (.406)	12.70 (.500)	13.13 (.517)	61.93 (2.438)	49.23 (1.938)	31.75 (1.250)	0.5 (.020)	18.256 ($\frac{23}{32}$)	9 230	21 600
POSB 7	77	11.112 (.4375)	-20UNF (.4375)	28.58 (1.125)	11.10 (.437)	14.27 (.562)	14.88 (.586)	68.28 (2.688)	53.98 (2.125)	34.93 (1.375)	0.5 (.020)	20.638 ($\frac{13}{16}$)	11 200	26 100
POSB 8	122	12.700 (.5000)	-20UNF (.5000)	33.32 (1.312)	12.70 (.500)	15.88 (.625)	17.73 (.698)	78.59 (3.094)	61.93 (2.438)	38.10 (1.500)	0.5 (.020)	23.812 ($\frac{15}{16}$)	14 800	36 200
POSB 10	186	15.875 (.6250)	-18UNF (.6250)	38.10 (1.500)	14.27 (.562)	19.05 (.750)	21.31 (.839)	85.73 (3.375)	66.68 (2.625)	41.28 (1.625)	0.5 (.020)	28.575 (1 $\frac{1}{8}$)	20 000	39 300
POSB 12	295	19.050 (.7500)	-16UNF (.7500)	44.45 (1.750)	17.45 (.687)	22.23 (.875)	24.84 (.978)	95.25 (3.750)	73.03 (2.875)	44.45 (1.750)	0.5 (.020)	33.338 (1 $\frac{5}{16}$)	28 500	55 000
POSB 16	1 129	25.400 (1.0000)	-12UNF (1.2500)	69.85 (2.750)	25.40 (1.000)	34.93 (1.375)	32.23 (1.269)	139.70 (5.500)	104.78 (4.125)	53.98 (2.125)	0.5 (.020)	47.625 (1 $\frac{7}{8}$)	59 300	112 000

Note⁽¹⁾ $r_{s\ min}$ stands for minimum allowable value of chamfer r .

Lubrication Type PILLOBALL Rod Ends **Die-cast Type/With Female Thread**

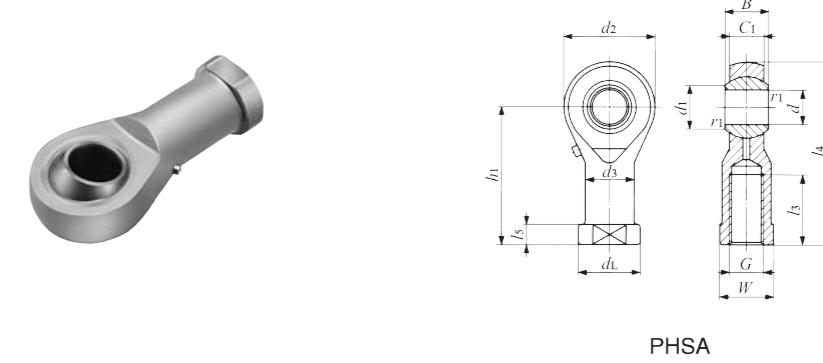

PHSA

Identification number	Mass (Ref.) g	Boundary dimensions mm															Static load capacity C_s N
		d	Thread G	d_2	C_1	B	d_1	l_4	h_1	l_3	l_5	W	d_3	d_L	$r_{s\ min}^{(1)}$	Ball dia. mm (inch)	
PHSA 5	17	5	M 5×0.8	17	6	8	7.7	35.5	27	16	4	9	9	11	0.2	11.112 ($\frac{7}{16}$)	5 470
PHSA 6	25	6	M 6×1	19.5	6.75	9	9	39.7	30	16	5	11	10	13	0.2	12.700 ($\frac{1}{2}$)	6 760
PHSA 8	45	8	M 8×1.25	24	9	12	10.4	48	36	19	5	14	12.5	16	0.2	15.875 ($\frac{5}{8}$)	10 200
PHSA 10	70	10	M10×1.5	28	10.5	14	12.9	57	43	23	6.5	17	15	19	0.2	19.050 ($\frac{3}{4}$)	13 100
PHSA 12	105	12	M12×1.75	32	12	16	15.4	66	50	27	6.5	19	17.5	22	0.2	22.225 ($\frac{7}{8}$)	16 400
PHSA 14	155	14	M14×2	36	13.5	19	16.9	75	57	30	8	22	20	25	0.3	25.400 (1)	20 000
PHSA 16	190	16	M16×2	40	15	21	19.4	84	64	36	8	22	22	27	0.3	28.575 (1 $\frac{1}{8}$)	23 900
PHSA 18	290	18	M18×1.5	45	16.5	23	21.9	93.5	71	40	10	27	25	31	0.3	31.750 (1 $\frac{1}{4}$)	28 800
PHSA 20	400	20	M20×1.5	49	18	25	24.4	101.5	77	43	10	30	27.5	34	0.3	34.925 (1 $\frac{3}{8}$)	33 400
PHSA 22	500	22	M22×1.5	54	20	28	25.8	111	84	47	12	32	30	37	0.3	38.100 (1 $\frac{1}{2}$)	40 400

Note⁽¹⁾ Minimum allowable value of chamfer dimension r_1

- Remarks1. A grease nipple is provided on the body.
 2. Not provided with prepacked grease. Perform proper lubrication for use.
 3. When a metric fine thread specification is required, please contact www.iko.com.

PILLOBALL

Maintenance-free Type PILLOBALL Rod Ends **With Female Thread**

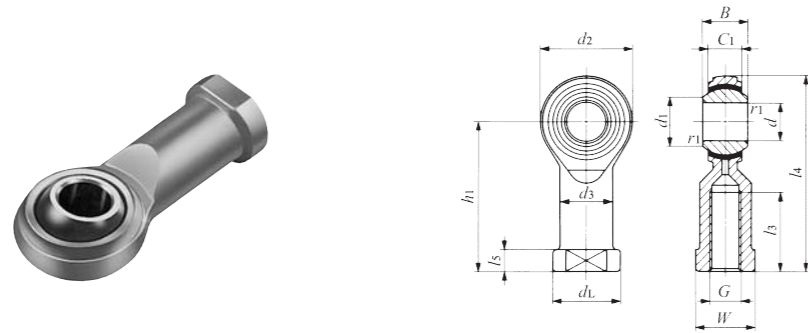

PHS...EC

Identification number	Mass (Ref.) g	Boundary dimensions mm														Dynamic load capacity C _d N	Static load capacity C _s N	
		d	Thread G	d ₂	C ₁	B	d ₁	l ₄	h ₁	l ₃	l ₅	W	d ₃	d _L	r _{1s min} ⁽¹⁾			Ball dia. mm (inch)
PHS 3EC	5.7	3	M 3×0.5	12	4.5	6	5.2	27	21	10	3	5.5	5	6.5	0.2	7.938 (5/16)	3 500	2 480
PHS 4EC	11.9	4	M 4×0.7	14	5.3	7	6.5	31	24	12	4	8	8	9.5	0.2	9.525 (3/8)	4 950	3 260
PHS 5EC	16.5	5	M 5×0.8	16	6	8	7.7	35	27	12.5	4	9	9	11	0.2	11.112 (7/16)	6 540	4 010
PHS 6EC	25	6	M 6×1	18	6.75	9	9	39	30	13.5	5	11	10	13	0.2	12.700 (1/2)	8 410	4 940
PHS 8EC	43	8	M 8×1.25	22	9	12	10.4	47	36	16	5	14	12.5	16	0.2	15.875 (5/8)	14 000	7 760
PHS 10EC	72	10	M10×1.5	26	10.5	14	12.9	56	43	19.5	6.5	17	15	19	0.2	19.050 (3/4)	19 600	10 500
PHS 12EC	107	12	M12×1.75	30	12	16	15.4	65	50	24	6.5	19	17.5	22	0.2	22.225 (7/8)	26 200	13 700
PHS 14EC	160	14	M14×2	34	13.5	19	16.9	74	57	27	8	22	20	25	0.2	25.400 (1)	33 600	17 200
PHS 16EC	210	16	M16×2	38	15	21	19.4	83	64	33	8	22	22	27	0.2	28.575 (1 1/8)	42 000	21 100
PHS 18EC	295	18	M18×1.5	42	16.5	23	21.9	92	71	36	10	27	25	31	0.2	31.750 (1 1/4)	51 400	25 100
PHS 20EC	380	20	M20×1.5	46	18	25	24.4	100	77	40	10	30	27.5	34	0.2	34.925 (1 3/8)	61 600	30 000
PHS 22EC	490	22	M22×1.5	50	20	28	25.8	109	84	41	12	32	30	37	0.2	38.100 (1 1/2)	74 700	36 400

Note⁽¹⁾ Minimum allowable value of chamfer dimension r₁
 Remarks1. Neither oil hole nor grease nipple is provided.
 2. When a metric fine thread specification is required, please contact IKO.

Maintenance-free Type PILLOBALL Rod Ends **With Male Thread**

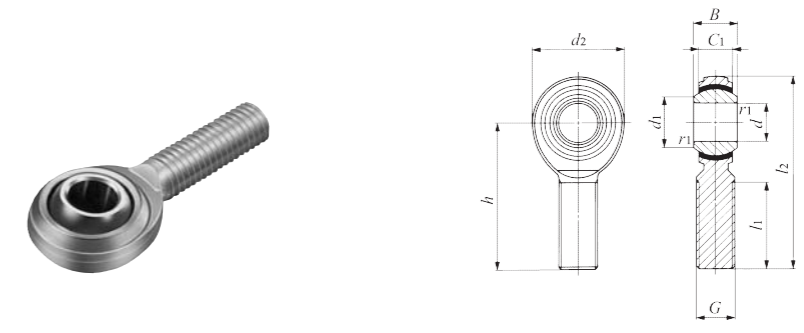

POS...EC

Identification number	Mass (Ref.) g	Boundary dimensions mm														Dynamic load capacity C _d N	Static load capacity C _s N
		d	Thread G	d ₂	C ₁	B	d ₁	l ₂	h	l ₁	r _{1s min} ⁽¹⁾	Ball dia. mm (inch)					
POS 3EC	5.0	3	M 3×0.5	12	4.5	6	5.2	33	27	15	0.2	7.938 (5/16)	3 500	1 220			
POS 4EC	8.1	4	M 4×0.7	14	5.3	7	6.5	37	30	17	0.2	9.525 (3/8)	4 950	2 060			
POS 5EC	12.5	5	M 5×0.8	16	6	8	7.7	41	33	20	0.2	11.112 (7/16)	6 540	3 340			
POS 6EC	19	6	M 6×1	18	6.75	9	9	45	36	22	0.2	12.700 (1/2)	8 410	4 730			
POS 8EC	32	8	M 8×1.25	22	9	12	10.4	53	42	25	0.2	15.875 (5/8)	14 000	7 760			
POS 10EC	54	10	M10×1.5	26	10.5	14	12.9	61	48	29	0.2	19.050 (3/4)	19 600	10 500			
POS 12EC	85	12	M12×1.75	30	12	16	15.4	69	54	33	0.2	22.225 (7/8)	26 200	13 700			
POS 14EC	126	14	M14×2	34	13.5	19	16.9	77	60	36	0.2	25.400 (1)	33 600	17 200			
POS 16EC	185	16	M16×2	38	15	21	19.4	85	66	40	0.2	28.575 (1 1/8)	42 000	21 100			
POS 18EC	260	18	M18×1.5	42	16.5	23	21.9	93	72	44	0.2	31.750 (1 1/4)	51 400	25 100			
POS 20EC	340	20	M20×1.5	46	18	25	24.4	101	78	47	0.2	34.925 (1 3/8)	61 600	30 000			
POS 22EC	435	22	M22×1.5	50	20	28	25.8	109	84	51	0.2	38.100 (1 1/2)	74 700	36 400			

Note⁽¹⁾ Minimum allowable value of chamfer dimension r₁
 Remarks1. Neither oil hole nor grease nipple is provided.
 2. When a metric fine thread specification is required, please contact IKO.